

6 Gbps SFP Transceiver (USFP-6LR2)

1310nm Single mode 20km Dual LC

Features

- Up to 6.25 to 10 Gb/s bit rates
- 1310nm wavelength DFB laser
- Hot-Pluggable
- Dual LC connector
- Up to 20km via SMF
- Monitoring Interface Compliant with SFF-8472
- Compliant to IEEE 802.3ae & SFP MSA
- Manufactured in an ISO 9001 compliant facility
- Operating temperature range: 0°C to 70°C
- ROHS-6 Compliant

Applications

- 6,25G Ethernet Switch and Enterprise Router
- 6,25G SONET OC-192 / SDH and Fibre Channel
- Other Optical Links

Part numbers

<i>P/N</i>	<i>Data Rate</i>	<i>Wavelength</i>	<i>Connector</i>	<i>Distance</i>
USFPP-6LR2	6,25Gbps	1310nm	LC	20km

Absolute Maximum Ratings

Parameter	Symbol	Min.	Typical	Max.	Unit
Storage Temperature	T _S	-40		+85	°C
Case Temperature	T _C	0		70	°C
Supply Voltage	V _{CC}	-0.5		4	V
Relative Humidity	RH	5		95	%

Recommended Operating Environment:

Parameter	Symbol	Min.	Typical	Max.	Unit
Case operating Temperature	T _C	0		70	°C
Supply Voltage	V _{CC}	3.14		3.47	V
Supply Current	I _{CC}			430	mA
Power Consumption				1	W

Electrical Characteristics (T_{OP} = 0 to 75°C, V_{CC} = 3.14 to 3.47 Volts)

Parameter	Symbol	Min.	Typical	Max.	Unit	Note
Transmitter Section:						
Input differential impedance	R _{in}		100		Ω	1
Single ended data input swing	V _{in PP}	180		700	mV	
Transmit Disable Voltage	V _D	2		V _{CC}	V	2
Transmit Enable Voltage	V _{EN}	V _{EE}		V _{EE} + 0.8	V	
Receiver Section:						
Single ended data output swing	V _{out,pp}	300		850	mv	3
Data output rise time	T _r	30			ps	3
Data output fall time	T _f	30			ps	4
LOS Fault	V _{losfault}	2		V _{CCHOST}	V	5
LOS Normal	V _{los norm}	V _{EE}		V _{EE} +0.8	V	5

Note:

1. AC coupled.
2. Or open circuit.
3. Into 100 ohm differential termination.
4. 20 – 80 %
5. LOS is an open collector output. Should be pulled up with 4.7k – 10kΩ on the host board. Normal operation is logic 0; loss of signal is logic 1. Maximum pull-up voltage is 5.5V.

Optical Parameters(T_{OP} = 0 to 70°C, V_{CC} = 3.14 to 3.47 Volts)

Parameter	Symbol	Min.	Typical	Max.	Unit	Note
Transmitter Section:						
Center Wavelength	λ _c	1270	1310	1350	nm	
RMS spectral width	σ			1	nm	
Optical Output Power	P _{out}	-8.2		0.5	dBm	1
Optical Power OMA	P _{oma}	-5.2			dBm	
Laser Off Power	P _{off}			-30	dBm	
Extinction Ratio	ER	3.5			dB	

6 Gbps SFP Transceiver (USFP-6LR2)

1310nm Single mode 20km Dual LC

Transmitter Dispersion Penalty	TDP			3.2	dB	2
Relative Intensity Noise	Rin			-128	dB/Hz	3
Receiver Section:						
Optical Input Wavelength	λ_c	1260		1620	nm	
Receiver Overload	P_{ol}	0.5			dBm	
RX Sensitivity	Sen			-14.4	dBm	4
RX_LOS Assert	LOS _A	-25			dBm	
RX_LOS De-assert	LOS _D			-15	dBm	
RX_LOS Hysteresis	LOS _H	0.5			dB	
General Specifications:						
Data Rate	BR		10		Gbps	
Bit Error Rate	BER			10^{-12}		
Max. Supported Link Length on 9/125 μ m SMF@10Gb/s	L _{MAX}			10	km	

Note

1. Average power figures are informative only, per IEEE802.3ae.
2. TWDP figure requires the host board to be SFF-8431 compliant. TWDP is calculated using the Matlab code provided in clause 68.6.6.2 of IEEE802.3ae.
3. 12dB reflection.
4. Conditions of stressed receiver tests per IEEE802.3ae. CSRS testing requires the host board to be SFF-8431 compliant.

Pin Assignment

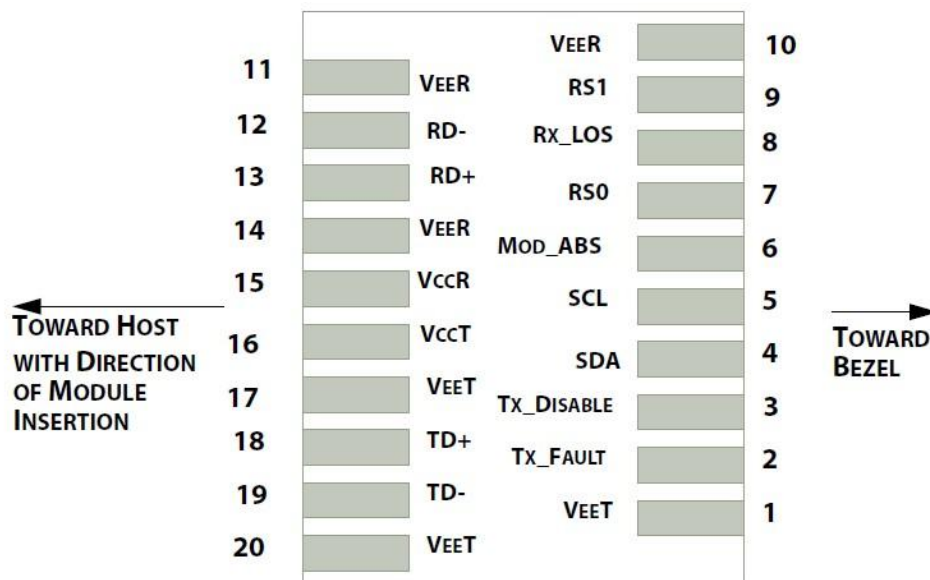

Pin Function Definitions

PIN #	Name	Function	Notes
1	VeeT	Module transmitter ground	1
2	Tx Fault	Module transmitter fault	2
3	Tx Disable	Transmitter Disable; Turns off transmitter laser output	3
4	SDL	2 wire serial interface data input/output (SDA)	
5	SCL	2 wire serial interface clock input (SCL)	
6	MOD-ABS	Module Absent, connect to VeeR or VeeT in the module	2
7	RS0	Rate select0, optionally control SFP+ receiver. When high, input data rate >4.5Gb/s; when low, input data rate <=4.5Gb/s	
8	LOS	Receiver Loss of Signal Indication	4
9	RS1	Rate select0, optionally control SFP+ transmitter. When high, input data rate >4.5Gb/s; when low, input data rate <=4.5Gb/s	
10	VeeR	Module receiver ground	1
11	VeeR	Module receiver ground	1
12	RD-	Receiver inverted data out put	
13	RD+	Receiver non-inverted data out put	
14	VeeR	Module receiver ground	1
15	VccR	Module receiver 3.3V supply	
16	VccT	Module transmitter 3.3V supply	
17	VeeT	Module transmitter ground	1
18	TD+	Transmitter inverted data out put	
19	TD-	Transmitter non-inverted data out put	
20	VeeT	Module transmitter ground	1

Note:

- 1.The module ground pins shall be isolated from the module case.
- 2.This pin is an open collector/drain output pin and shall be pulled up with 4.7K-10Kohms to Host_Vcc on the host board.
- 3.This pin shall be pulled up with 4.7K-10Kohms to VccT in the module.
- 4.This pin is an open collector/drain output pin and shall be pulled up with 4.7K-10Kohms to Host_Vcc on the host board.

SFP Module EEPROM Information and Management

The SFP modules implement the 2-wire serial communication protocol as defined in the SFP -8472. The serial ID information of the SFP modules and Digital Diagnostic Monitor parameters can be accessed through the I²C interface at address A0h and A2h. The memory is mapped in Table 1. Detailed ID information (A0h) is listed in Table 2. And the DDM specification at address A2h. For more details of the memory map and byte definitions, please refer to the SFF-8472, “Digital Diagnostic Monitoring Interface for Optical Transceivers”. The DDM parameters have been internally calibrated.

Table 1. Digital Diagnostic Memory Map (Specific Data Field Descriptions)

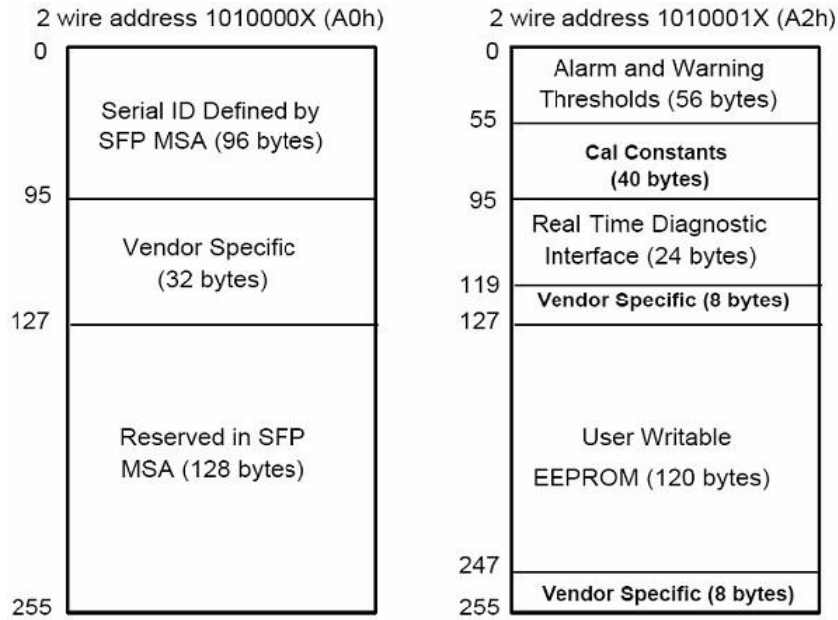

Table 2 - EEPROM Serial ID Memory Contents (A0h)

Data Address	Length (Byte)	Name of Length	Description and Contents
Base ID Fields			
0	1	Identifier	Type of Serial transceiver (03h=SFP)
1	1	Reserved	Extended identifier of type serial transceiver (04h)
2	1	Connector	Code of optical connector type (07=LC)
3-10	8	Transceiver	10G Base-ZR
11	1	Encoding	64B/66B
12	1	BR, Nominal	Nominal baud rate, unit of 100Mbps
13-14	2	Reserved	(0000h)
15	1	Length(9um)	Link length supported for 9/125um fiber, units of 100m
16	1	Length(50um)	Link length supported for 50/125um fiber, units of 10m
17	1	Length(62.5um)	Link length supported for 62.5/125um fiber, units of 10m
18	1	Length(Copper)	Link length supported for copper, units of meters
19	1	Reserved	
20-35	16	Vendor Name	SFP vendor name
36	1	Reserved	
37-39	3	Vendor OUI	SFP transceiver vendor OUI ID
40-55	16	Vendor PN	Part Number (ASCII)
56-59	4	Vendor rev	Revision level for part number
60-62	3	Reserved	

6 Gbps SFP Transceiver (USFP-6LR2)

1310nm Single mode 20km Dual LC

63	1	CCID	Least significant byte of sum of data in address 0-62
Extended ID Fields			
64-65	2	Option	Indicates which optical SFP signals are implemented (001Ah = LOS, TX_FAULT, TX_DISABLE all supported)
66	1	BR, max	Upper bit rate margin, units of %
67	1	BR, min	Lower bit rate margin, units of %
68-83	16	Vendor SN	Serial number (ASCII)
84-91	8	Date code	Manufacturing date code
92-94	3	Reserved	
95	1	CCEX	Check code for the extended ID Fields (addresses 64 to 94)
Vendor Specific ID Fields			
96-127	32	Readable	Specific date, read only
128-255	128	Reserved	Reserved for SFF-8079

Digital Diagnostic Monitor Characteristics

Data Address	Parameter	Accuracy	Unit
96-97	Transceiver Internal Temperature	±3.0	°C
98-99	VCC3 Internal Supply Voltage	±3.0	%
100-101	Laser Bias Current	±10	%
102-103	Tx Output Power	±3.0	dB
104-105	Rx Input Power	±3.0	dB

Regulatory Compliance

The TSPLXGA0D complies with international Electromagnetic Compatibility (EMC) and international safety requirements and standards (see details in Table following).

Electrostatic Discharge (ESD) to the Electrical Pins	MIL-STD-883E Method 3015.7	Class 1(>1000 V)
Electrostatic Discharge (ESD) to the Duplex LC Receptacle	IEC 61000-4-2 GR-1089-CORE	Compatible with standards
Electromagnetic Interference (EMI)	FCC Part 15 Class B EN55022 Class B (CISPR 22B) VCCI Class B	Compatible with standards
Laser Eye Safety	FDA 21CFR 1040.10 and 1040.11 EN60950, EN (IEC) 60825-1,2	Compatible with Class 1 laser product.

Recommended Circuit

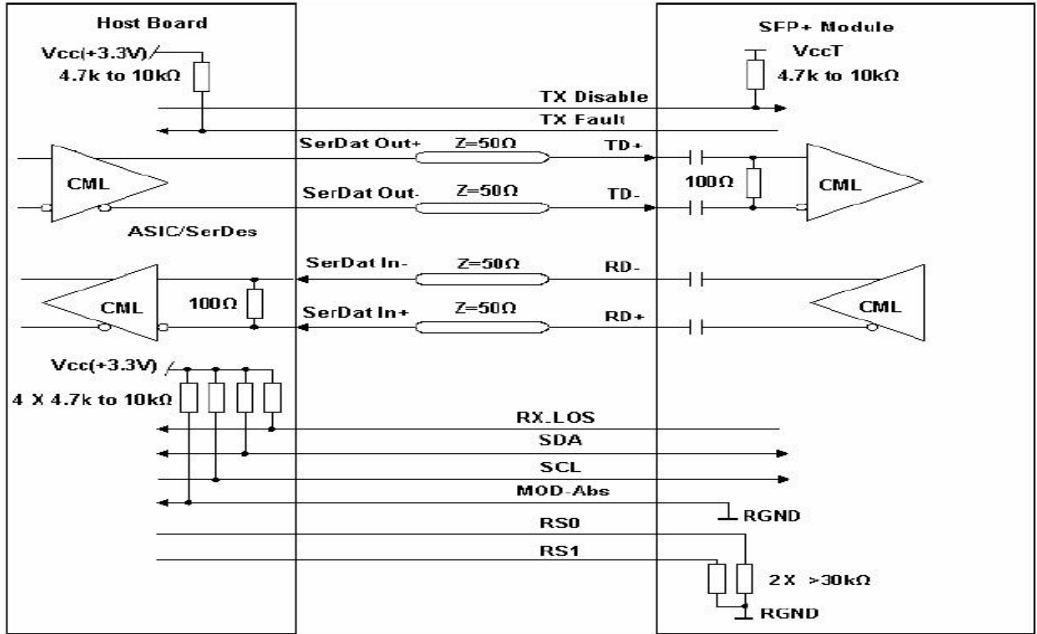
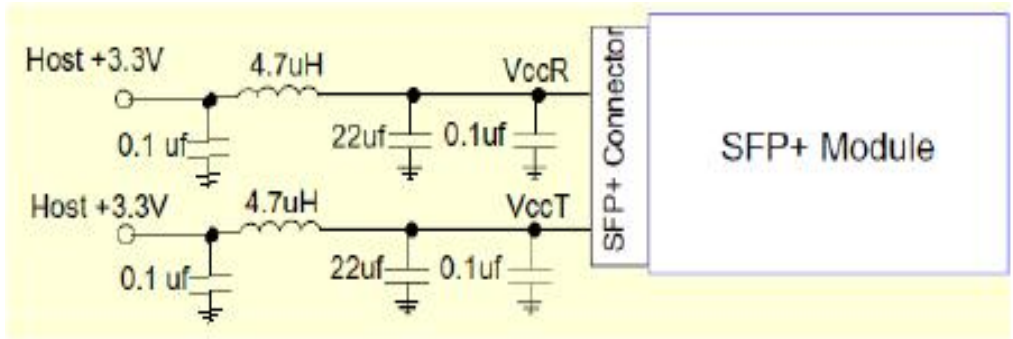

Recommended High-speed Interface Circuit

6 Gbps SFP Transceiver (USFP-6LR2)

1310nm Single mode 20km Dual LC

Mechanical Dimensions (All dimension are $\pm 0.20\text{mm}$ unless Otherwise specified, unit: mm)

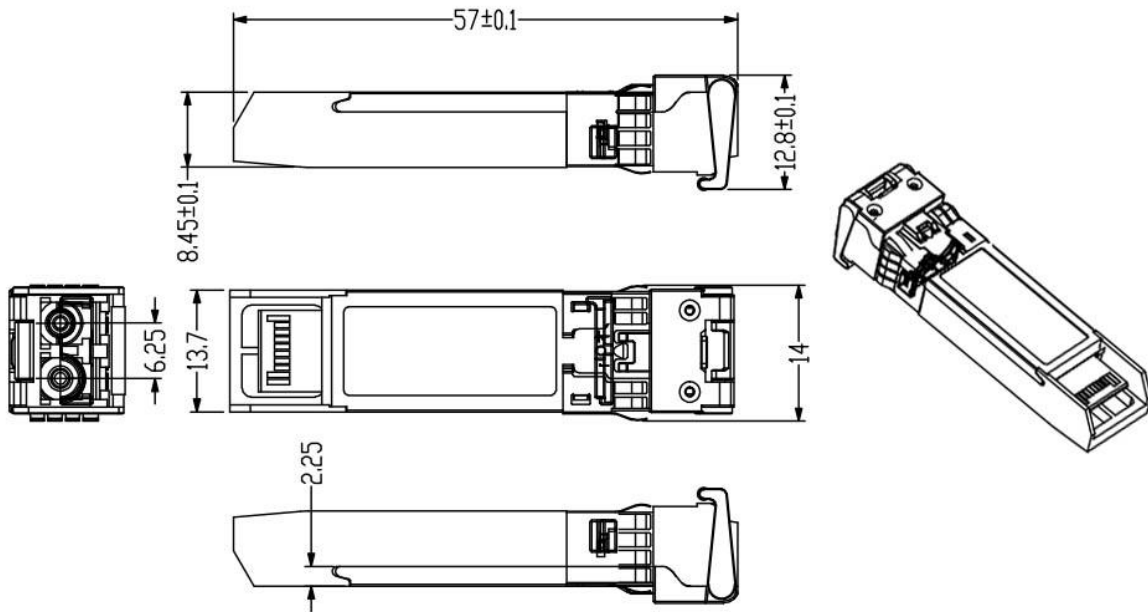

For More Information

USource Technology
F8 Huameiju, Yulv RD
Shenzhen China 518102
Tel. +68-755-23014563
info@usourcetek.com
www.usourcetek.com